

# Schaerer Coffee Celebration

Model "BCL" (coffee, hot water, steam, milk)

September 2007



## Basic configuration

Spouts: coffee / hot water / steam	1 / 1 / 1
Boiler: coffee (3kW) / hot water (6kW) / steam (3kW)	1 / 1 / 1
Grinders / DECAF function	2 / 1
Programmable product selection	up to 30 products
Fridge	1

## Connections

Voltage / power / fuse protection	400 V 3NAC / 9.3 kW / 16 A
Water connection / water outlet	G ½ " max 3 bar / min. Ø 40mm
Water hardness	5°-7° dh / 8°-12° fh

## Dimensions

Width / depth / height	756 / 617 / 893.5 mm
Weight	about 90 kg

## Output per hour (approximate)

Espresso (cup of 50 - 60ml)	240
Coffee (cup of 120ml)	200
Cappuccino (cup of 180ml)	180
Latte Macchiato (cup of 200ml)	160
Cold milk / hot milk (litre)	180 / 180
Hot water (litre)	30 - 40

## Options

3 grinders and DCAF / 4 grinders without DECAF
Fresh and waste water tanks
Chute for coffee grounds under counter
Brewing accelerator
Cup warmer
Bean container short / Lockable bean containers
Connection to all commercial invoicing systems

## Dimensions

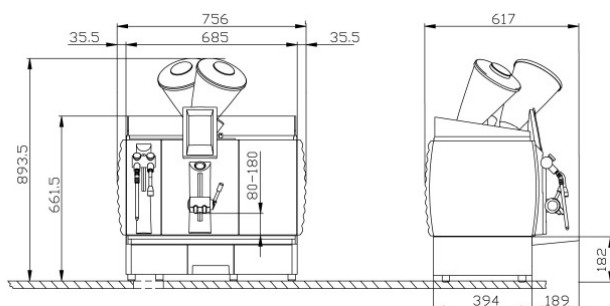

Differences between the offered machine and the picture/configuration are possible.

## Colours

Illustrations may not reflect actual colour

	Blue Mountain, blue
	Costa Rica, silver
	Brazil, bronze
	Kenya, black
	Base frame – stainless steel
	Base frame - stainless steel black

M. Schaerer Ltd.  
 Gewerbestrasse 15  
 CH - 3302 Moosseedorf  
 Phone +41 (0)31 858 51 11  
 Fax +41 (0)31 858 51 40  
 info@schaerer.com  
 www.schaerer.com

**schaerer**<sup>®</sup>  
 coffee comes to life